



FABRICATED SLIDE VALVES

ROTOLUX

everything under control...

• FABRICATED SLIDE VALVES •

INTRODUCTION

The Rotolok industrial range of slide valves are simply, but robustly, designed to handle powders, pellets and granules over a wide field of applications. They may be operated manually, or by pneumatic means or electric motors, and offer reliable, continuous service with the minimum of attention and maintenance.

The standard range covers most needs, but the basic designs are capable of fabrication to any specified sizes and construction.

IMPORTANT FEATURES

- No jamming. All slide plates run on flanged rollers.
- Minimal leakage. All valves (except enclosed valves) fitted with packing gland type seals.
- Streamlined design means unrestricted material flow.

All add up to Rotolok standards.

RANGE

Wide standard range of manual, motorized, pneumatic versions, suitable for all usual flow handling applications. Special sizes fabricated on request.

SPECIFICATION

Body

Carbon or Stainless Steel from 1/8 inch plate.

Side Plates

Carbon or Stainless Steel.

Hand Wheel and Chain Wheel

Rack and Pinion.

Solenoid Valves

Five port four way single solenoid spring return.

Limit Switches

Micro switches to IP55.

Motors

1/8hp TEFC motor with torque limiter to prevent overload.

Rollers

Flanged MS oilite bushes or nylon.



FABRICATED SLIDE VALVES

MANUAL SQUARE SLIDE
The basic model in the range, designed for straightforward, easy push-pull manual operation.

PLANNING IN DETAILS FOR GENERAL GUIDANCE ONLY

Drillings are Rotolok standards. Variations can be made.

VALVE SIZE	SIZE	A	B	C	D	E	F	G	H	J	K
VALVE SIZE	6	6	9 1/2	2	4	8	3/8	13 3/4	4	1 7/8	13
	6 1/2	6 1/2	10	2	4 1/4	8	3/8	14 1/4	4	1 7/8	13 7/8
	8	8	11 7/16	2	5	8	3/8	15 11/16	4	1 7/8	16
	8 1/2	8 1/2	12	2	5 1/4	8	3/8	16 1/4	4	1 7/8	16 7/8
	10	10	13 1/2	2	5 7/8	8	1/2	17 3/8	4	1 7/8	19 1/4
	10 1/2	10 1/2	14	2	6 1/4	8	3/8	17 7/8	4	1 7/8	19 7/8
	12	12	15 3/8	4	3 7/16	16	1/2	19 1/8	4	1 7/8	23 3/4
	12 1/2	12 5/8	16 1/8	4	3 5/8	16	1/2	20 3/8	4	1 7/8	23
	14	13 3/4	17 3/8	4	15 3/4	16	1/2	21	4	1 7/8	24 3/4
	14 1/2	14 9/16	18 1/8	4	4 1/8	16	1/2	22 3/8	4	1 7/8	26
	16	16	19 1/2	4	4 7/16	16	1/2	24 3/8	4	1 7/8	29 3/4
	16 1/2	16 1/2	20	3	6 1/8	12	11/16	24 3/8	4	1 7/8	29 1/4

Dimensions in inches unless stated

Dimension subject to change without notice

RACK AND PINION SQUARE SLIDE
Provides a finer degree of manual control for metering, etc. Fitted with handwheel or, alternatively, a chain wheel for operating at varying heights above floor level.

PLANNING IN DETAILS FOR GENERAL GUIDANCE ONLY

Drillings are Rotolok standards. Variations can be made.

VALVE SIZE	SIZE	A	B	C	D	E	F	G	H	J	L	X	Y
VALVE SIZE	6 1/2	6 1/2	10	2	4 1/4	8	5/16	16	4	1	1 3/4	3 5/8	7 7/8
	8	8	11 1/2	2	4 15/16	8	5/16	18 3/4	4	1	1 3/4	3 5/8	7 7/8
	8 1/2	8 1/2	12	2	5 1/4	8	5/16	19 3/4	4	1	1 3/4	3 5/8	7 7/8
	10	10	13 1/2	2	5 7/8	8	5/16	22 7/8	4	1	1 3/4	3 5/8	7 7/8
	10 1/2	10 1/2	14	2	6 1/4	8	5/16	24	4	1	1 3/4	3 5/8	7 7/8
	12	12	15 3/8	4	3 7/16	16	3/8	26 7/8	4	1	1 3/4	3 5/8	7 7/8
	12 1/2	12 5/8	16 1/8	4	3 5/8	16	3/8	28	4	1	1 3/4	3 5/8	7 7/8
	14	14	17 9/16	3	5 5/16	12	3/8	30 7/8	4	1	1 3/4	3 5/8	8
	14 1/2	14 1/2	18 1/8	4	4 1/8	16	3/8	32 1/4	4	1	1 3/4	3 5/8	7 7/8
	16	16	19 1/2	4	4 7/16	16	3/8	34 3/4	4	1	1 3/4	3 5/8	7 7/8
	16 1/2	16 1/2	20	4	4 5/8	16	3/8	36	4	1	1 3/4	3 5/8	7 7/8

Dimensions in inches unless stated

Dimension subject to change without notice

FABRICATED SLIDE VALVES

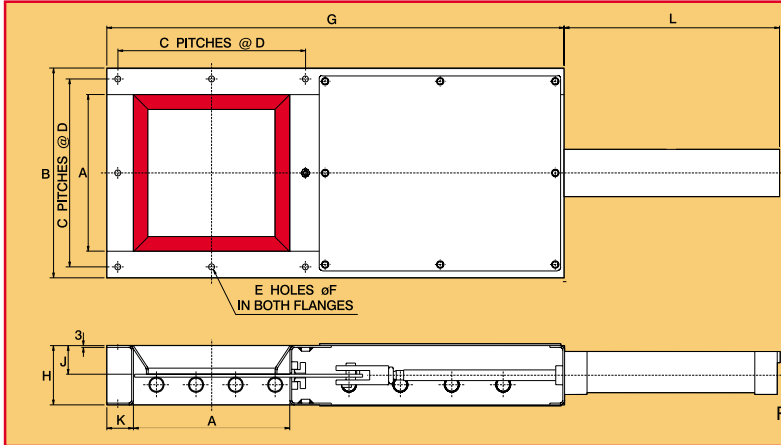

SINGLE SQUARE PNEUMATIC SLIDE

Also based on the standard manual valve but fitted with one cylinder for medium duty applications.

PLANNING IN DETAILS FOR GENERAL GUIDANCE ONLY

Drillings are Rotolok standards. Variations can be made.

VALVE SIZE	SIZE	A	B	C	D	E	F	G	H	J	K	L
VALVE SIZE	6	6	9 1/2	2	4	8	5/16	20 7/8	4	1 1/2	1 3/4	9 3/4
	6 1/2	6 1/2	10	2	4 1/4	8	5/16	21 3/8	4	1 7/8	1 3/4	9 1/2
	8	8	11 1/2	2	5	8	5/16	21 3/8	4	1 7/8	1 3/4	10
	8 1/2	8 1/2	12	2	5 1/4	8	5/16	26 1/4	4	1 7/8	1 7/8	12 3/8
	10	10	13 5/8	2	5 7/8	8	5/16	27 7/8	4	1 7/8	1 3/4	12 1/2
	10 1/2	10 1/2	14	2	6 1/4	8	5/16	30 3/8	4	1 7/8	1 7/8	14 3/8
	12	12	15 9/16	4	3 9/16	16	3/8	31 13/16	4	1 7/8	1 3/4	15
	12 1/2	12 5/8	16 1/8	4	3 5/8	16	3/8	34 3/8	4	1 7/8	1 3/4	17
	14	13 7/8	17 3/8	4	4	16	3/8	35 5/16	3 15/16	1 7/8	1 3/4	16 5/16
	14 1/2	14 9/16	18 1/8	4	4 1/8	16	3/8	37 1/16	3 15/16	1 7/8	1 3/4	18 5/16
	16	15 3/4	19 5/16	4	4 7/16	16	3/8	38 1/4	3 15/16	1 7/8	1 3/4	18 5/16
	16 1/2	16 1/2	20 1/8	4	4 5/8	16	3/8	42 1/4	4	1 7/8	1 3/4	20 7/8

Dimensions in inches unless stated

Dimension subject to change without notice

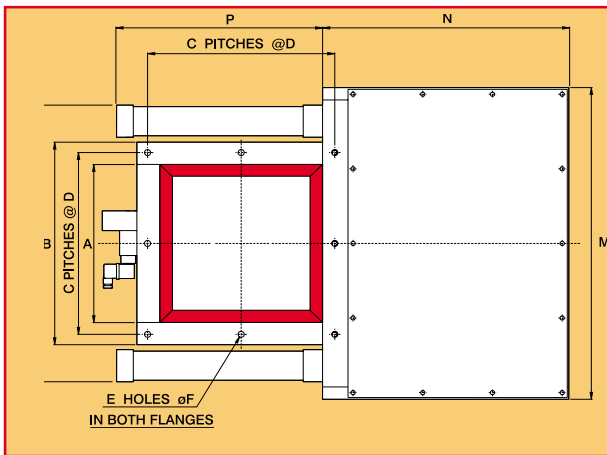

DOUBLE SQUARE PNEUMATIC SLIDE

Based on the standard manual valve and fitted with two double acting cylinders and one four-way solenoid valve and limit switches. Compact and robust design of enclosed construction.

PLANNING IN DETAILS FOR GENERAL GUIDANCE ONLY

Drillings are Rotolok standards. Variations can be made.

VALVE SIZE	SIZE	A	B	C	D	E	F	H	J	K	L	M	N	P	Q
VALVE SIZE	6	6	9 1/2	2	3 15/16	8	5/16	4	1 7/8	1 3/4	2 5/8	18 1/8	12 1/4	9 1/8	15 5/16
	6 1/2	6 1/2	10	2	4 1/4	8	5/16	4	1 7/8	1 3/4	2 5/8	18 1/8	12	9 1/4	16
	8	8	11 1/2	2	5	8	5/16	4	1 7/8	1 7/8	2 3/4	20 5/8	13 1/8	10 1/8	17 3/4
	8 1/2	8 1/2	12	2	5 3/4	8	5/16	4	1 7/8	1 3/4	2 3/4	20 3/8	15	12 1/4	17 3/8
	10	10	13 1/2	2	5 7/8	8	5/16	4	1 7/8	1 7/8	2 5/8	22 1/2	15	12 1/8	19 1/2
	10 1/2	10 1/2	14	2	6 1/4	8	5/16	4	1 7/8	1 3/4	2 3/16	22 1/2	17 1/8	14 1/4	19 1/2
	12	12	15 3/8	4	3 7/16	16	3/8	4	1 7/8	1 3/4	2 3/4	26 1/8	17 7/8	14 1/4	21 1/4
	12 1/2	12 5/8	16 1/8	4	3 5/8	16	3/8	4	1 7/8	1 7/8	2 3/4	24 7/8	19	16 1/8	22
	14	14	17 1/2	4	3 15/16	16	3/8	4	1 7/8	1 7/8	2 3/4	26 1/4	19 7/8	17	23 1/2
	14 1/2	14 1/2	18 1/8	4	4 1/8	16	3/8	4	1 7/8	1 3/4	2 15/16	27	19 3/4	18 15/16	24
	16	16	19 1/2	4	4 7/16	16	3/8	4	1 7/8	1 5/16	2 3/4	28 3/8	21 1/8	18 1/8	25 5/8
	16 1/2	16 1/2	20 1/8	4	4 5/8	16	3/8	4	1 7/8	1 7/8	2 5/8	29	23	20 1/8	26

Dimensions in inches unless stated

Dimension subject to change without notice

• FABRICATED SLIDE VALVES •

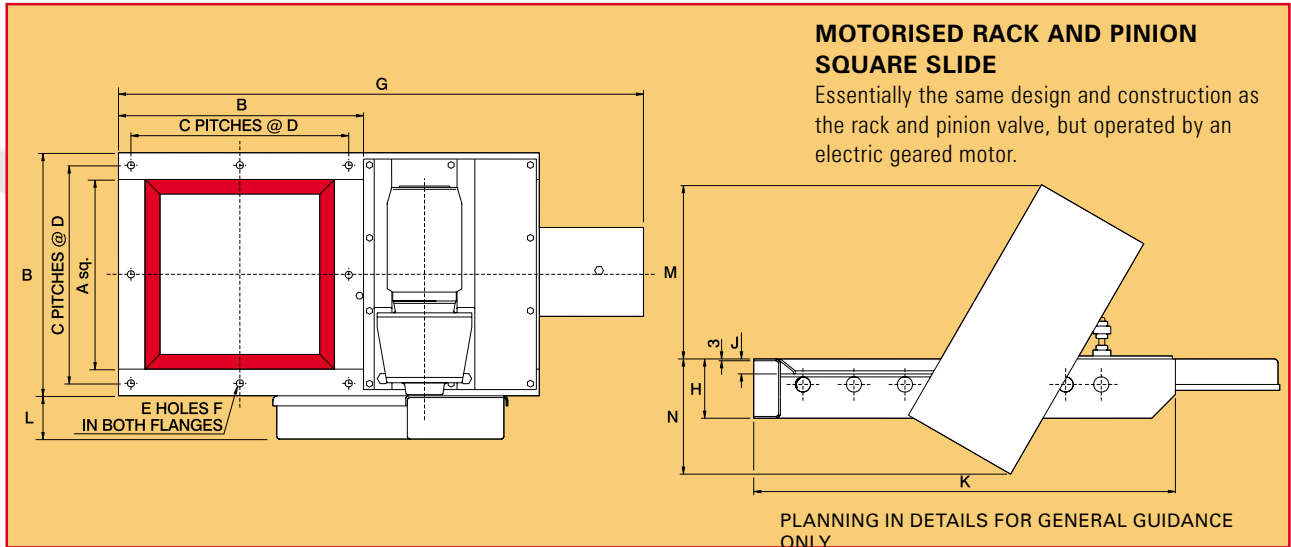

Drillings are Rotolok standards. Variations can be made.

VALVE SIZE	SIZE	A	B	C	D	E	F	G	H	J	K	L	M	N
12	12	12	12	17 3/8	3	5	8	11/16	34 5/8	4	1	27 3/4	3 1/4	7 3/4

Dimensions in inches unless stated

Dimension subject to change without notice

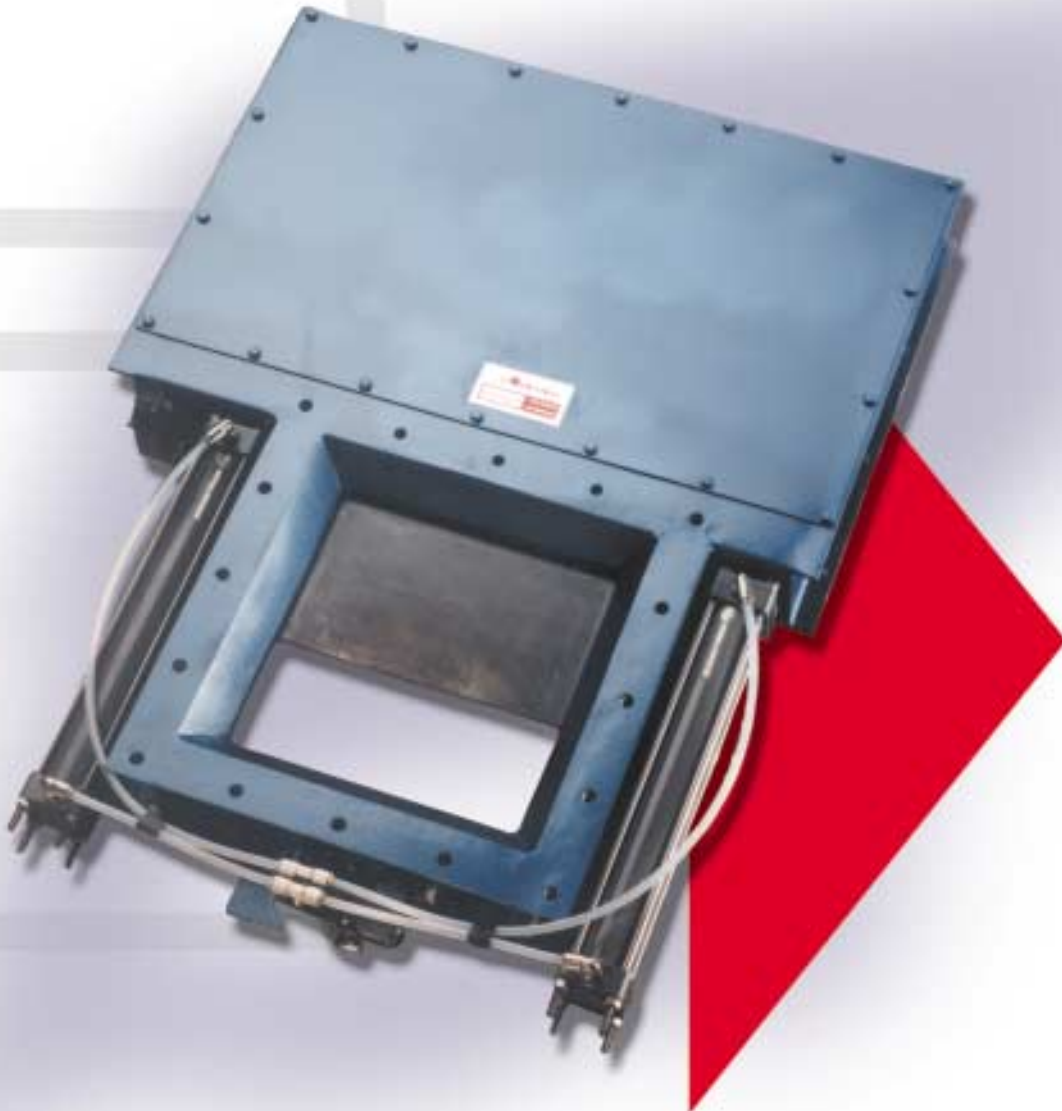

• OTHER ROTOLOK PRODUCTS •

- Rotary Airlocks
- Conveying Diverters
- Double Dumps
- Fabricated Slides
- Slim Slides
- Rotoslides
- Rotoflex Valves
- Slimflex Valves
- Butterfly Dampers
- Weigh Valves
- Plug Diverters
- Screw Conveyors
- Gravity Diverters
- Rotospeed Switch
- Level Lok
- Pipe Couplings
- Ni Hard Bends
- Special Designs



Rotolok Valves Inc
Industrial Ventures II, 2711 Gray Fox Road
Monroe, North Carolina, 28110
Tel: (704) 282-4444 Fax: (704) 282-4242
e-mail: sales@rotolok.com
website: www.rotolok.com